

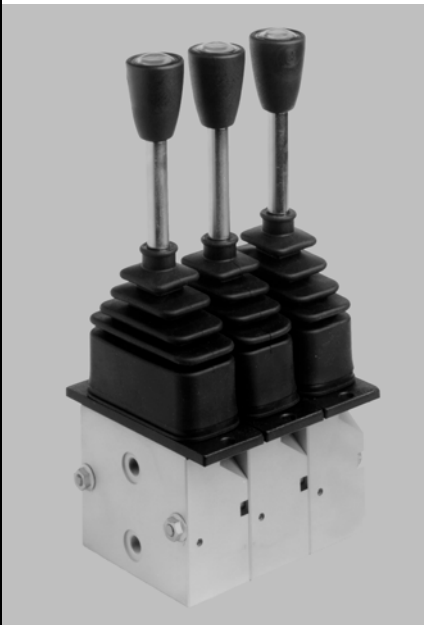

$\$P_{01}$



$\$P_{10}/\P_{30}

PNEUMATIC REMOTE CONTROL VALVES



Features

This catalog presents the **SP** pneumatic remote control valves with high metering characteristics for proportional control of directional control valves.

- SP01 - SP10 monoblock body SP30 or stackable.
- Aluminum body.
- Low actining efforts.
- Easy installation.
- Frictions, detents, safety lever, several types of knob available.

Working conditions

This catalog shows technical specifications and diagrams measured at ambient temperature of 20°C (68°F).

Maximum feeding pressure		10 bar	145 psi
Air flow at 7 bar (102 psi)		350 dm ³ /min	12.4 ft ³ /min
Ambient temperature range		from -40° to 60°C	from -40°F to 140°F
Tie rod tightening torque	<i>SP30 only</i>	30 Nm	22.2 lb ft
Standard threads	<i>NPT</i>	1/8-27	
Stud ends tightening torque	<i>All ports</i>	15 Nm	11 lb ft
Weight	<i>SP01</i>	2,5 kg	5,5 lb
	<i>SP10 - SP11</i>	1,7 kg	3.7 lb
	<i>SP30</i>	see table on page 8	

NOTE - For different conditions please contact Sales Dept.

Additional information

This catalog shows the product in the most standard configurations.
Please contact Sales Dpt. for more detailed information or special request.

WARNING!

All specifications of this catalog refer to the standard product at this date.
Walvoil, oriented to a continuous improvement, reserves the right to discontinue, modify or revise the specifications, without notice.

WALVOIL IS NOT RESPONSIBLE FOR ANY DAMAGE CAUSED BY AN
INCORRECT USE OF THE PRODUCT.

4rd edition February 2003:

This edition supercedes all prior documents.

Measured with 501MA pressure control curve on work ports.

Piloting pressure

SP01

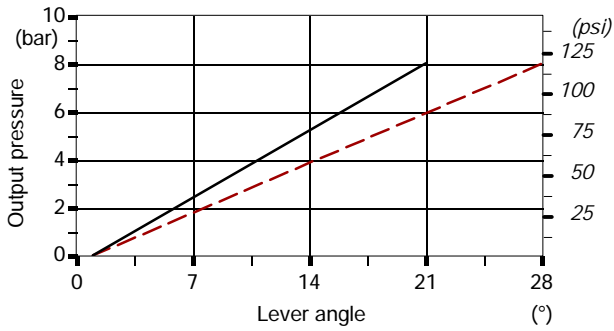

— Single port - - - Two contemporary

SP10-SP30

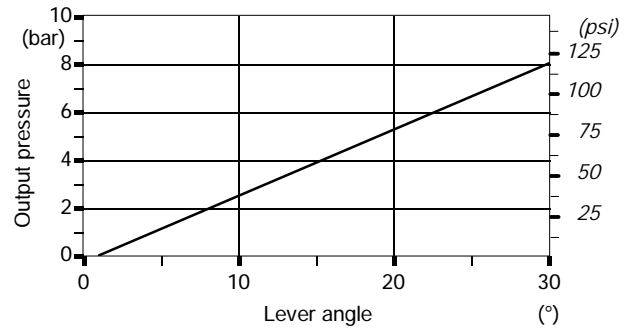

Actioning force

SP01

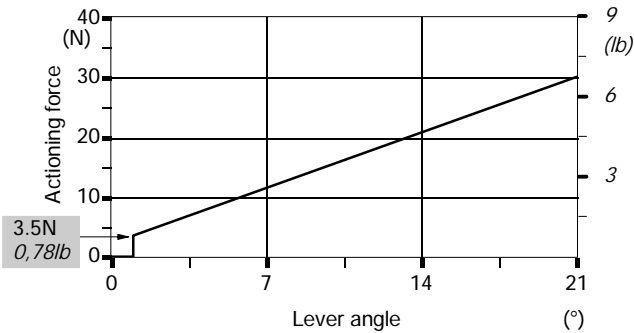

— Single port

SP10-SP30

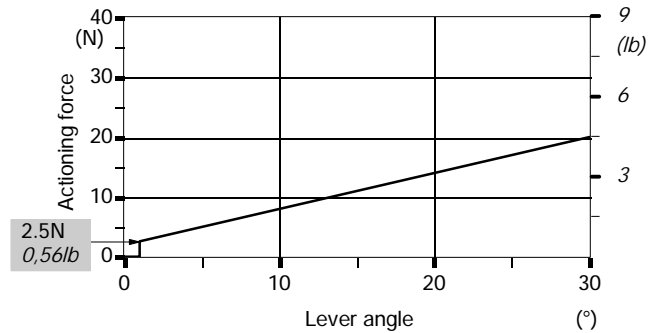

NOTE - Pivot distance from actioning point = 150mm - 5.90 in

Dimensional data and hydraulic circuit

Monoblock joystick with 1 lever and 4 work ports, for operation of 2 valve sections.
Bottom all ports.

Movements

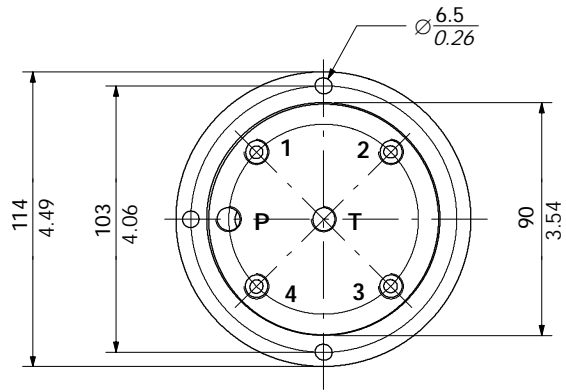
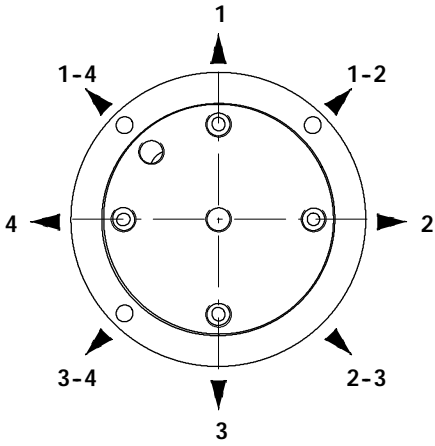

Circuit

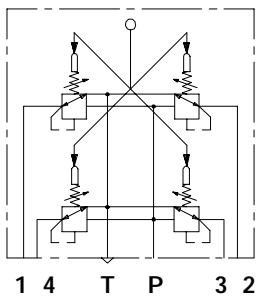

2 simultaneously work ports Single work port

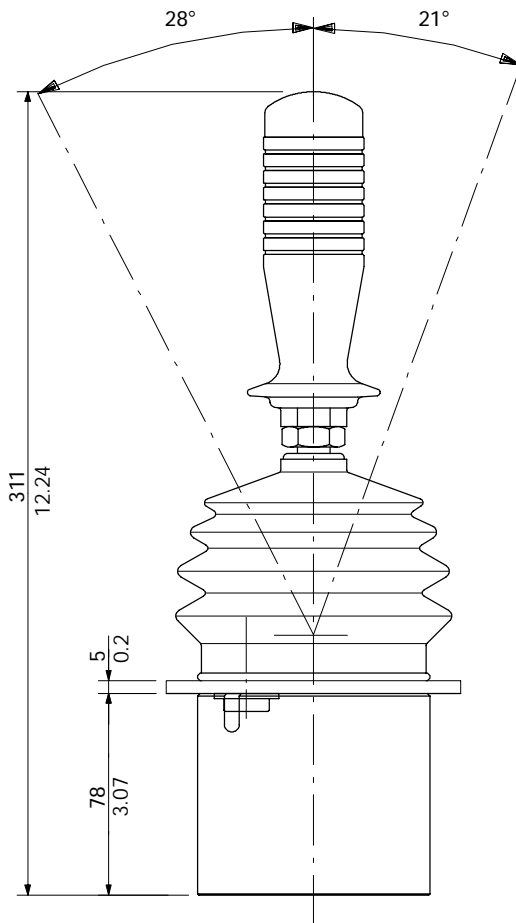

Description example:

SP 01 - N / 01 W1 - 501 A x 4

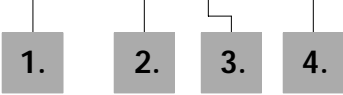

1. SP body kit

TYPE	CODE	DESCRIPTION
01-N	5CO4010500	Body kit

2. Kinematic kit

page 10

TYPE	CODE	DESCRIPTION
01	5ART310100	spring return to neutral

3. Handles with joint

TYPE	CODE	DESCRIPTION
W1	5IMP522000	less micro (standard)
X1	5IMP532000	n.1 micro with push-button
K1	5IMP542000	n.1 micro with recessed push-button
Z1	5IMP502000	n.1 micro with detented rocker-switch
Y1	5IMP512000	n.2 micro with spring return to neutral rocker-switch
T1	5IMP552000	n. 2 micro with detented 3 position rocker-switch

For different handles see page 11 and ask related catalogue DHR001E.

2.+3. Kinematic kits with handle

page 10

For assembling reasons, the under listed kinematic kits must be supplied complete with handle. Please contact our Sales Department for use with different handles.

TYPE	CODE	DESCRIPTION
02Y	5CIN902	with detent in neutral and type Y knob

4. Pressure control curve 501A

TYPE	CODE	DESCRIPTION
501A	5CUR501MA	without step, from 0 to 8 bar / 0 to 116 psi

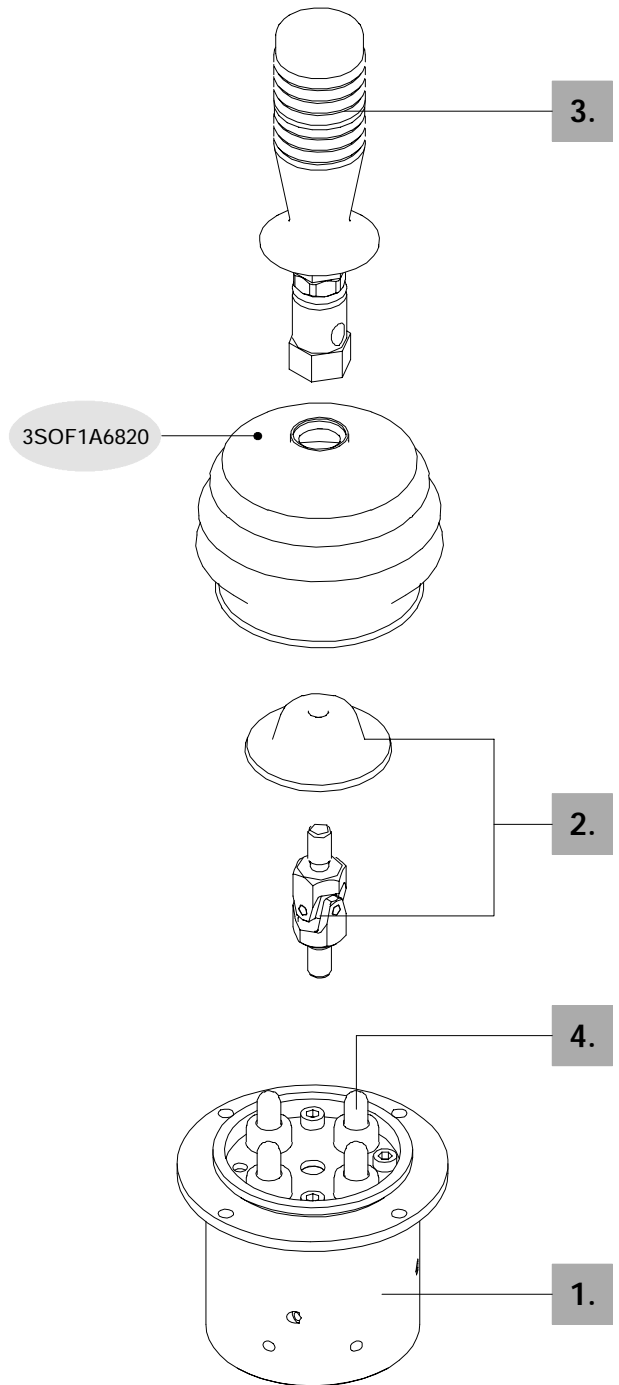

Dimensional data and hydraulic circuit

Monoblock with 1 lever and 2 work ports.
Side P and T ports.

Circuit

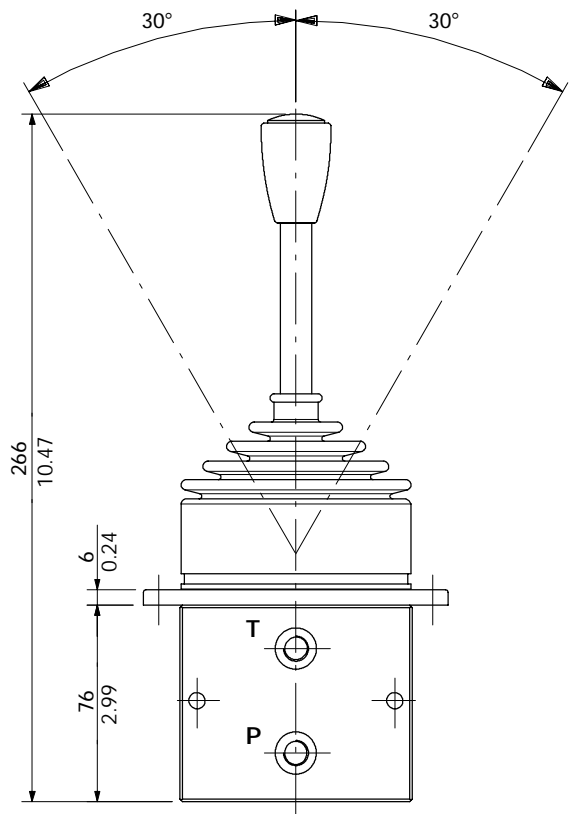
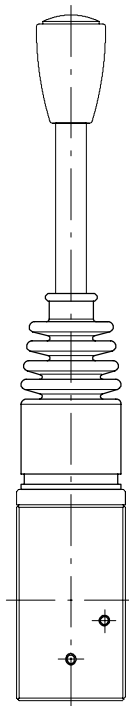
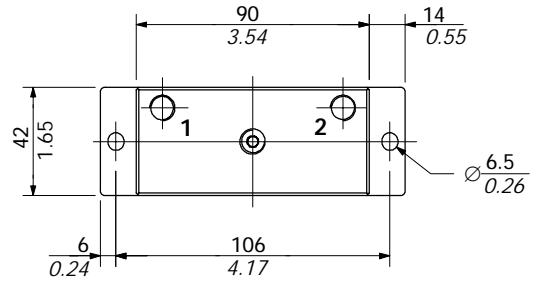
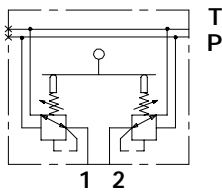

Description example:

SP 10 - N / 01 G3 - 501 A x 2

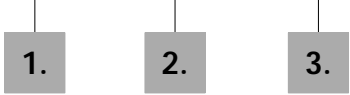

1. SP body kit

TYPE	CODE	DESCRIPTION
10-N	5CO4100500	Body kit

2. Kinematic kits with handle *page 10*

For assembling reasons, the under listed kinematic kits must be supplied complete with handle. Please contact our Sales Department for use with different handles.

TYPE	CODE	DESCRIPTION
01G3	5CIN901000	spring centered, G knob
02G3	5CIN904000	with detent in neutral, G knob
05G3	5CIN907000	with detent in position 1, G knob
06G3	5CIN907000	with detent in position 2, G knob
07G3	5CIN905000	with detent in position 1 and 2, G knob

3. Pressure control curve 501A

TYPE	CODE	DESCRIPTION
501A	5CUR501MA	without step, from 0 to 8 bar / 0 to 116 psi

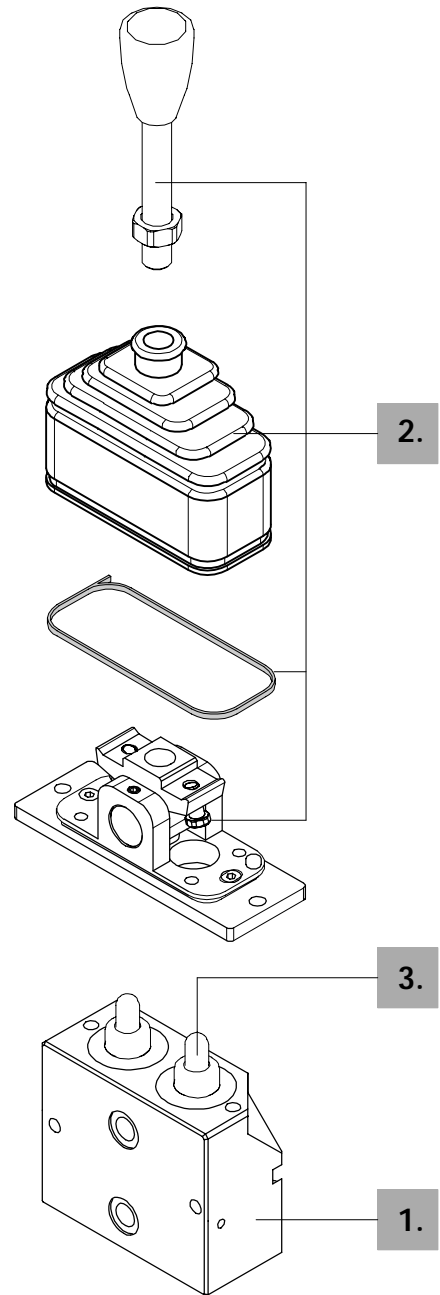

Dimensional data and hydraulic circuit

It's composed from nr.2 to 8 of single sections.
Side P and T ports.

Circuit

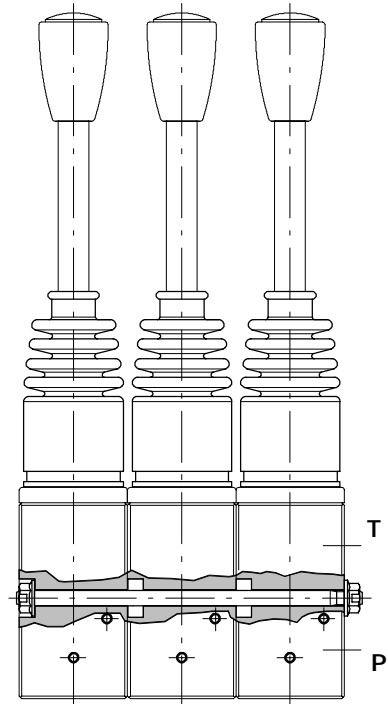
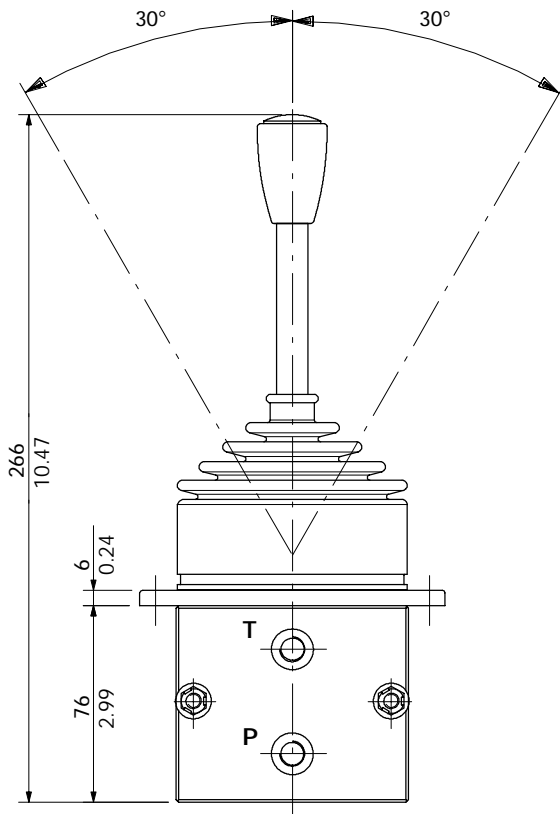
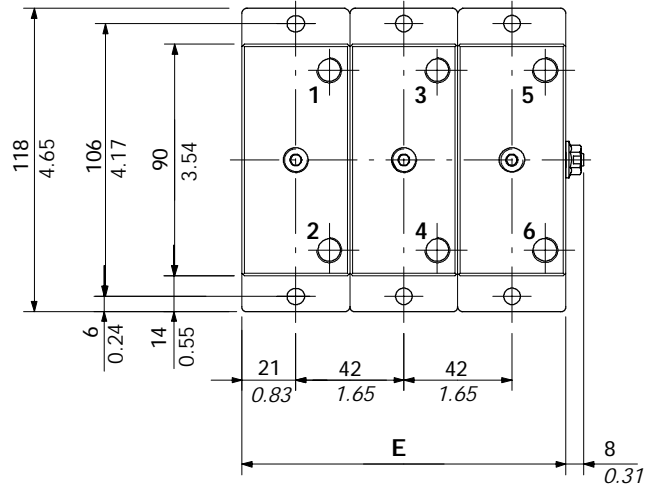
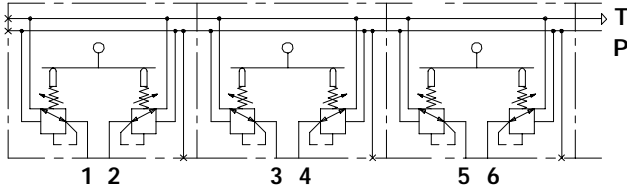

Pneumatic pilot control valves dimensions

TYPE	E		Weight	
	mm	in	kg	lb
SP30/2	84	3.31	3.4	7.4
SP30/3	126	4.96	5.1	11.1
SP30/4	168	6.61	6.8	14.8

TYPE	E		Weight	
	mm	in	kg	lb
SP30/5	210	8.27	8.5	18.5
SP30/6	252	9.92	10.2	22.2
SP30/7	294	11.57	11.9	25.9

TYPE	E		Weight	
	mm	in	kg	lb
SP30/8	336	13.23	13.6	29.6

SP01 kinematic kits

Type 01

Spring centered to neutral position.

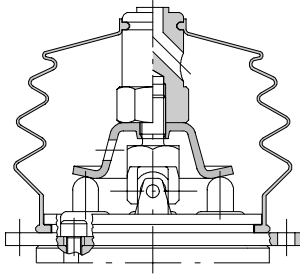

Type 02

With lock in neutral positions.
Unlock moving up knob.

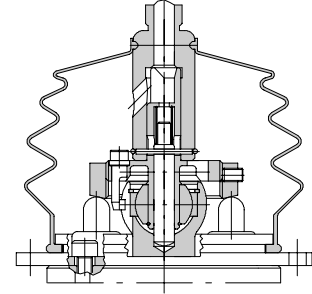

SP10-SP30 kinematic kits

Type 01

Spring centered to neutral positions.

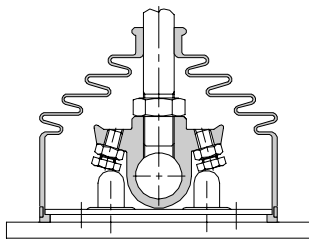

Type 02

With lock in neutral positions.
Unlock moving up knob.

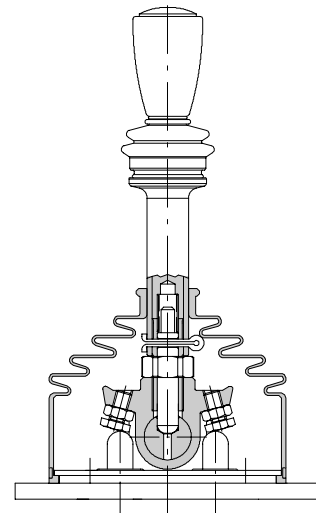

Controls with detent

Type 05

Detent in position 1, spring centered to neutral positions.

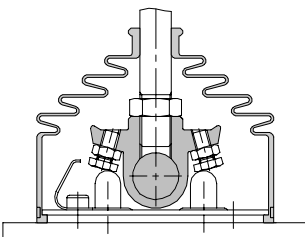

Type 06

Detent in position 2, spring centered to neutral positions.

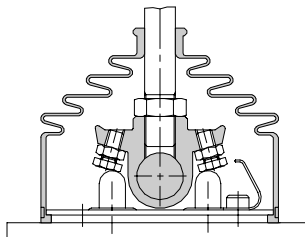

Type 07

Detent in position 1 and 2, spring centered to neutral positions.

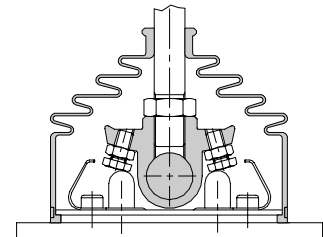

Handles with switches

Series **V** and **H** handles assembled on joystick **SP01** are available.

For any further information, please contact Sales Dept. or ask the related catalogue **DHR001A**.

Series V

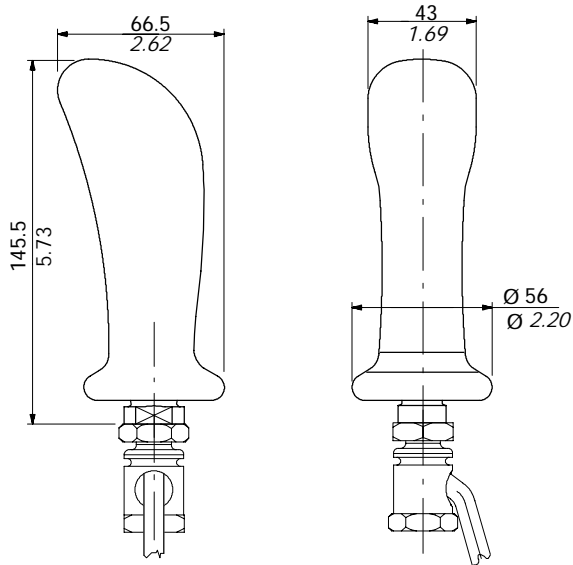

Available types

- Type **V**: available without switches or fitted with push-button or rocker switch (front of upper position)
- Type **VM**: fitted up to 4 (nr.1 upper and nr.3 front) push-buttons with 100/200mA current capability.
- Type **VT**: fitted up to 4 (nr.1 upper and nr.3 front) push-buttons with 5A current capability

Series H

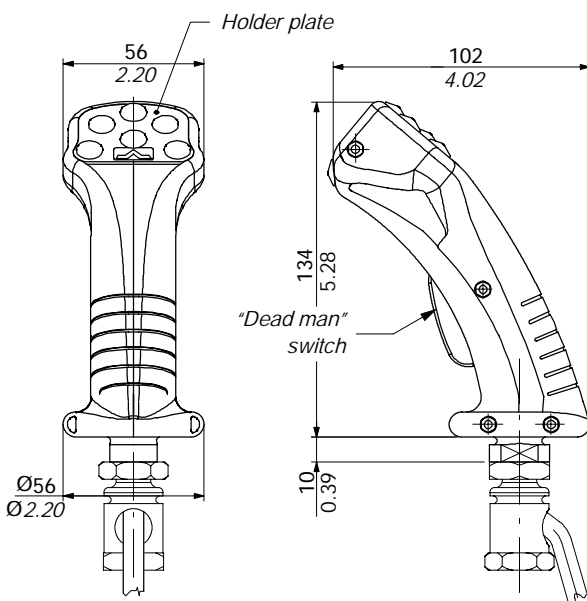

Available types

- Type **H**: fitted up to 8 microswitch push-button, with rocker switch and "dead man" switch
- Type **HM**: fitted up to 4 push-buttons (100/200mA types), with "dead man" and ON/OFF switches
- Type **HT**: fitted up to 4 push-buttons (5A types), with rocker switch, "dead man" and ON/OFF switches
- Type **HZ**: with potentiometer, fitted up to 2 microswitch push-button, "dead man" and ON/OFF switches



WALVOIL S.P.A.

42100 REGGIO EMILIA • ITALY • VIA ADIGE, 13/D
TEL. +39.0522.932411 • FAX +39.0522.300984
E-MAIL: INFO@WALVOIL.COM • HTTP: //WWW.WALVOIL.COM

SALES DEPARTMENT

TEL. +39.0522.932555 • FAX +39.0522.932455

DFC020A